

P/N: 29422-201

Copyright

© 2020, FLIR Systems, Inc.

All rights reserved worldwide. Names and marks appearing herein are either registered trademarks or trademarks of FLIR Systems and/or its subsidiaries. All other trademarks, trade names or company names referenced herein are used for identification only and are the property of their respective owners.

Document identity

Publ. No.: 29422-201

Commit: 61324

Language:

Modified: 2019-11-20

Formatted: 2020-05-14

Website

<http://www.flir.com>

Customer support

<http://support.flir.com>

Disclaimer

Specifications subject to change without further notice. Camera models and accessories subject to regional market considerations. License procedures may apply. Products described herein may be subject to US Export Regulations. Please refer to exportquestions@flir.com with any questions.



Detector data	
Detector Type	FLIR Indium Antimonide (InSb)
Spectral Range	3.0 – 5.0 μm
Resolution	1280 x 1024
Detector Pitch	12 μm
Thermal Sensitivity/NETD	≤ 30 mK (≤ 25 mK typical)
Well Capacity	Gain 0: 3.0 Me-, Gain 1: 11.5 Me-
Operability	$\geq 99.5\%$ ($\geq 99.9\%$ typical)
Sensor Cooling	Linear Sterling Cooler
Electronics	
Readout Type	Snapshot
Readout Modes	Asynchronous integrate while read Asynchronous integrate then read
Synchronization Modes	Genlock, Sync-in, Sync-out
Image Time Stamp	Internal IRIG-B decoder clock TSPI accurate time stamp
Integration Time	270 ns to 687 sec
Pixel Clock	355 MHz
Frame Rate (Full Window)	Programmable; 0.0015 Hz to 181 Hz
Subwindow Mode	Flexible windowing down to 64 x 4 (steps of 32 columns, 4 rows)
Dynamic Range	14-bit
On-Camera Image Storage	RAM (volatile): 16 GB, up to 6,100 frames, full frame SSD (non-volatile): >4 TB
Radiometric Data Streaming	Simultaneous Gigabit Ethernet (GigE Vision), Camera Link, CoaXPress (CXP)
Standard Video	HDMI, SDI, NTSC, PAL
Command and Control	GigE, USB, RS-232, Camera Link, CXP (GenICam protocol supported over GigE or CXP)

P/N: 29422-201

© 2020, FLIR Systems, Inc.

#29422-201; r. 61324;

Temperature Measurement	
Standard Temperature Range (with band matched optics)	-20°C to 350°C (-4°F to 662°F) -10°C for microscopes
Optional Temperature Range (with band matched optics)	45°C to 600°C (ND1) 250°C to 2000°C (ND2) 500°C to 3000°C (ND3)
Accuracy	≤ 100°C ±2°C (±1°C typical) > 100°C ±2% of reading (±1% typical)
Ambient Drift Compensation (with factory cal)	Yes
Optics	
Camera f/Number	f/2.5
Available Lenses (Uses FLIR HDC Optics)	17 mm, 25 mm, 50 mm, 100 mm, 200 mm
Close-up Lenses/Microscopes	1X
Lens Interface	FLIR HDC (4-tab bayonet)
Focus	Manual
Filtering	4-position motorized filter wheel, standard 1-inch filters
Image/Video Presentation	
Palettes	Selectable 8-bit
Automatic Gain Control	Manual, Linear, Plateau equalization, ROI, DDE
Overlay	Customizable
Video Modes	HD: 720p/50/59.9 Hz, 1080p/25/29.9 Hz, SD: NTSC, PAL
Digital Zoom	1x, 4x, 4:3
General	
Operating Temperature Range	-20°C to 50°C (-4°F to 122°F)
Shock/Vibration	40 g, 11 msec ½ sine pulse/4.3 g RMS random vibration, all 3 axes
Power	24 VDC (< 50 W steady state)
Weight w/Handle, w/o Lens	6.35 kg (14 lbs)
Size (L x W x H) w/o Lens, Handle	249 x 157 x 147 mm (9.8 x 6.2 x 5.8 in.)
Mounting	<ul style="list-style-type: none"> • 2 x ¼ in. -20 • 1 x 3/8 in. -16 • 4 x #10 -24 • Side: 3 x ¼ in. -20 (each side)

Supplies & accessories:

- 4215502; Lens 3-5 um 100 mm f/2.5 HDC Bayonet
- 4215423; Lens 3-5 um 17 mm f/2.5 HDC Bayonet
- 4215504; Lens 3-5 um 200 mm f/2.5 HDC Bayonet
- 4215425; Lens 3-5 um 25 mm f/2.5 HDC Bayonet
- 4215500; Lens 3-5 um 50 mm f/2.5 HDC Bayonet
- 4214995; Lens 3-5 um, 1X microscope, f/2.5 HDC Bayonet
- 4219797; Lens 3-5 um, 3X microscope, f/2.5 HDC Bayonet
- 4142360; ResearchIR Max HSDR CAMERA LINK CORE2 2TB (computer not included)
- 4142361; ResearchIR Max HSDR COXPRESS CORE2PLUS 2TB KIT (computer not included)



FLIR X8501sc

P/N: 29422-201

© 2020, FLIR Systems, Inc.

#29422-201; r. 61324;

- 4142363; ResearchIR Max Portable HSDR CAMERA LINK CORE2 2TB (computer included)
- 4142362; ResearchIR Max Portable HSDR COAXPRESS CORE2PLUS 2TB (computer included)
- 4222208; ResearchIR Max HSDR CAMERA LINK CORE2 4TB (computer not included)
- 4222209; ResearchIR Max HSDR COAXPRESS CORE2PLUS 4TB KIT (computer not included)
- 4223016; ResearchIR Max Portable HSDR CAMERA LINK CORE2 4TB (computer included)
- 4222995; ResearchIR Max Portable HSDR COAXPRESS CORE2PLUS 4TB (computer included)
- 4222206; Spare 4TB SSD Shuttle (4x960GB SSDs)
- 4220499; FLIR Research Studio - 1 Year Subscription (online activation)
- 4220500; FLIR Research Studio - Perpetual License (online activation)
- 4220646; FLIR Research Studio - Perpetual License (USB dongle)
- INST-EW-0000; Extended Warranty - Manual pricing
- INST-EWGM-0000; Premium Service Package - Manual pricing
- INST-GM-0200; General Maintenance for RS6700, A67XXsc, A6604, SC4000, SC610X, SC670X, SC8000, SC8X4X, SC820X, SC6000, X85XXsc, X68XXsc, X69XXsc

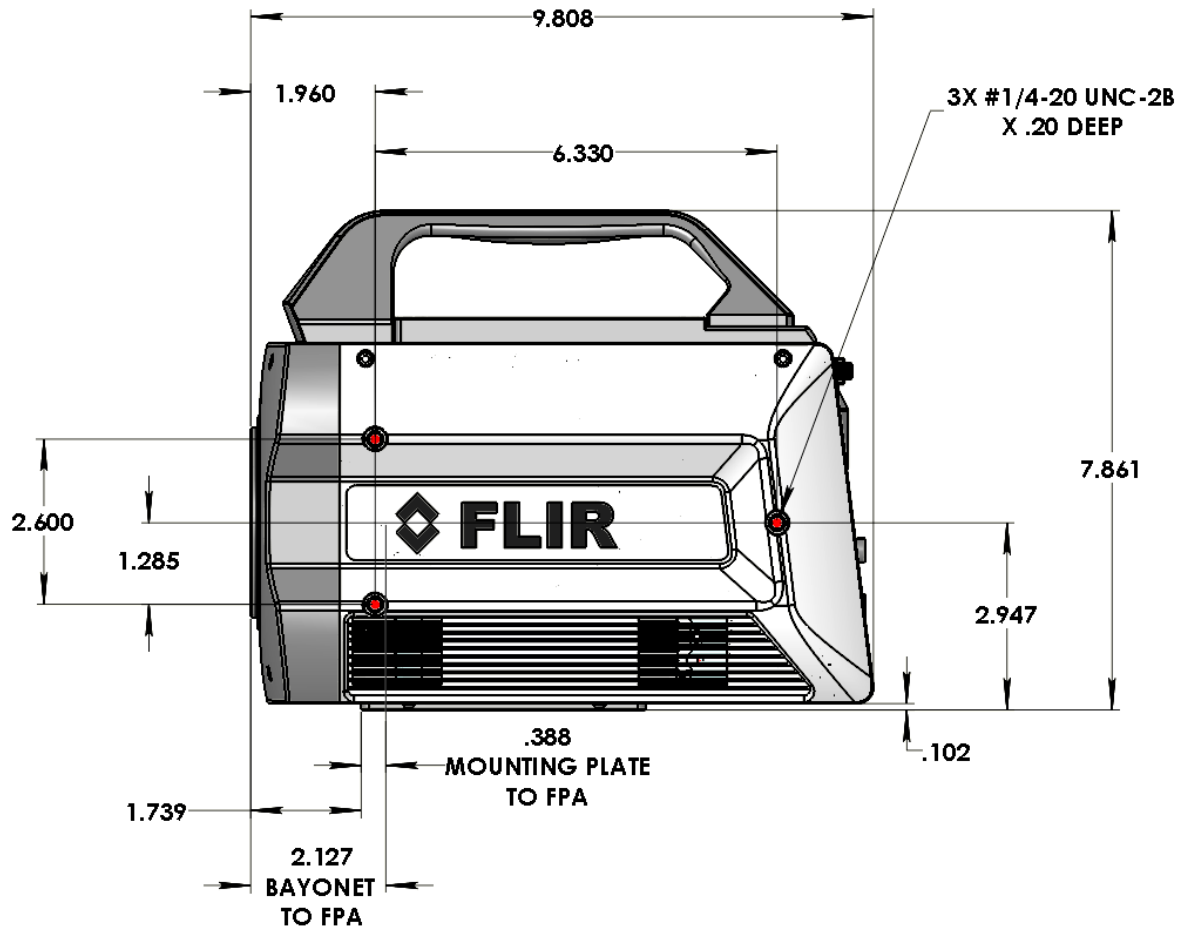

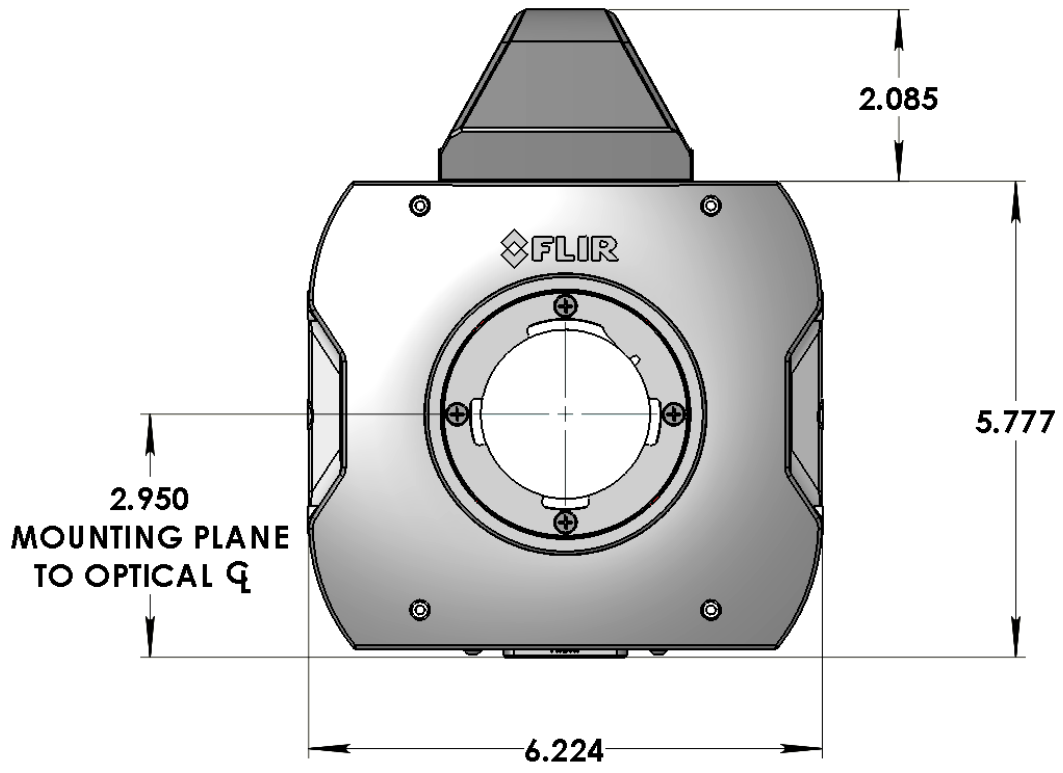

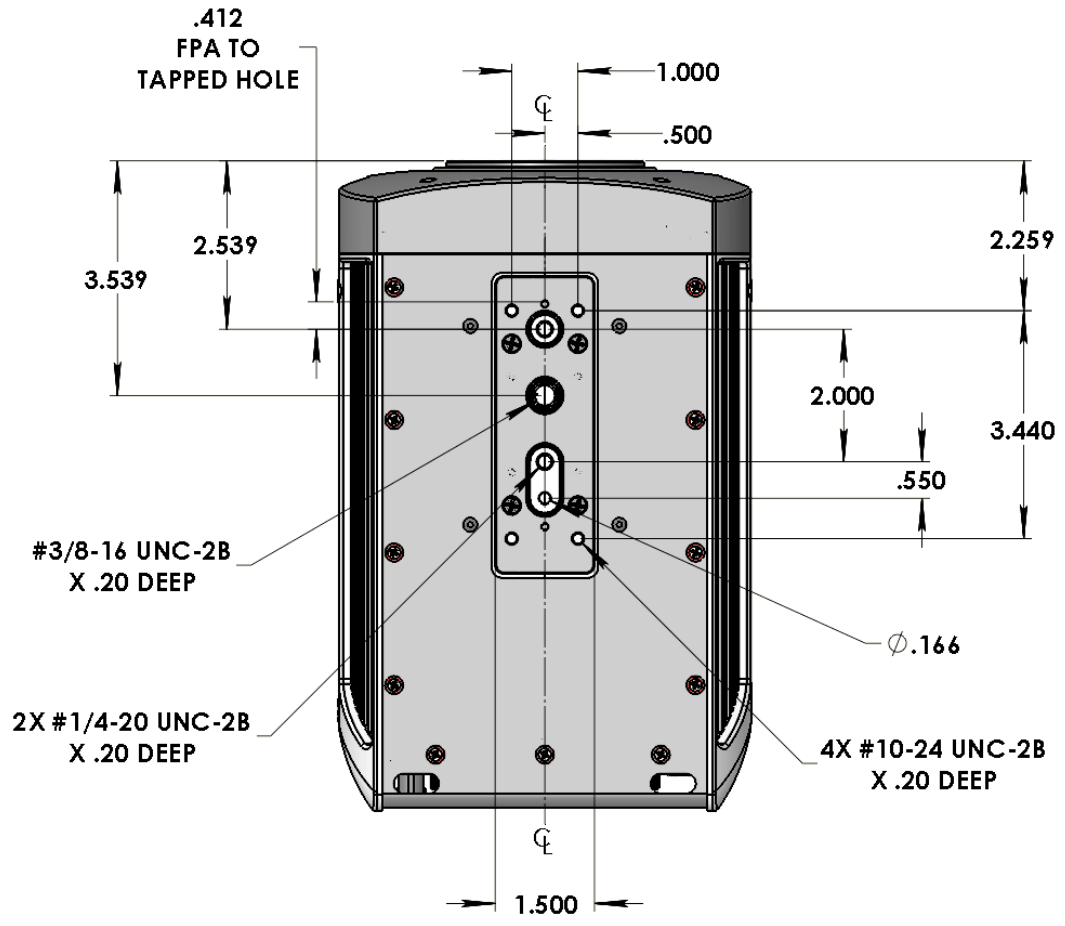



The World's Sixth Sense™

May 13, 2020 Niceville, Florida

CE Declaration of Conformity – EU Declaration of Conformity

Product: FLIR X6x00sc -series (GHP platform)
FLIR X8500sc -series (GHP platform)

Name and address of the manufacturer:

FLIR Systems, Inc.
4579 E Hwy 20
Suite 101
Niceville, FL 32578

This declaration of conformity is issued under the sole responsibility of the manufacturer.

The objects of the declaration:

- FLIR X6800sc -series (FLIR part numbers 29420-2xx)
- FLIR X6900sc -series (FLIR part numbers 29267-2xx)
- FLIR X6900sc SLS -series (FLIR part numbers 29421-2xx)
- FLIR X8500sc -series (FLIR part numbers 29422-2xx)
- FLIR X8500sc SLS -series (FLIR part numbers 29428-2xx)

The objects of the declaration described above is in conformity with the relevant Union harmonization legislation:

Directives:

Directive	2015/863/EU	RoHS
Directive	2014/30/EU	Electromagnetic Compatibility

Standards:

Emission	EN 61000-3-2:2014	EMC Limits for harmonic current emissions
	EN 61000-3-3:2013	EMC Limitation of voltage changes
	EN 55032:2012	EMC of multimedia equipment – Emissions requirements
Immunity	EN 55024:2010	Information Tech Equipment Immunity Characteristics

FLIR Systems, Inc.

Brian Cromwell
VP Product Development, R&D/Science Solutions